

INSTALLATION INSTRUCTIONS

SELF LEVELING RADAR ANTENNA MOUNT MODEL 400G

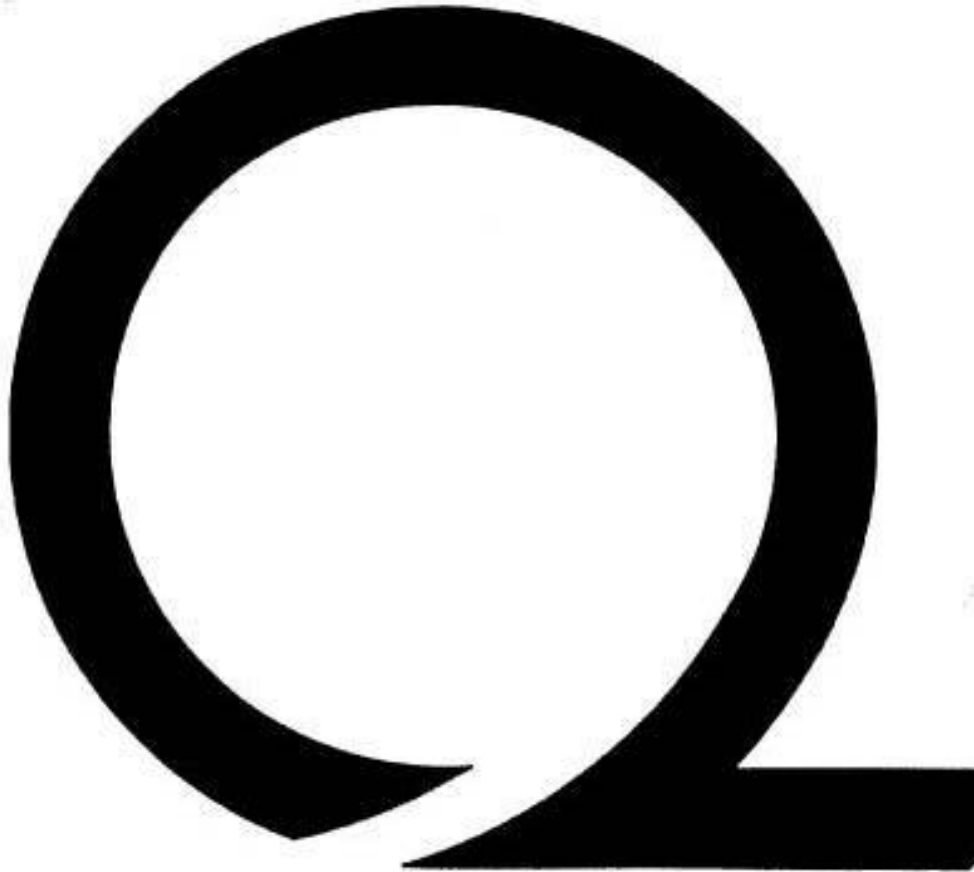

QUESTUS MARINE, INC.
PO BOX 9
MARBLEHEAD, MA 01945
1-800-RADAR66
TEL 781.639.1900
FAX 781.639.1905
www.QuestusMarine.com

**INSTALLATION INSTRUCTIONS
MODEL 400G
QUESTUS SELF LEVELING RADAR MOUNT**

Please carefully read the following instructions before installing your Model 400G Questus Self Leveling Radar Mount.

BEFORE YOU BEGIN:

A. The Model 400G is designed for use with most Marine Radar Antennae up to 18 inches in diameter.

B. The Model 400G has six different configurations to best fit your vessel:

DECK MOUNT

1. Radome forward – pole forward of the backstay
2. Radome forward – pole aft of the backstay
3. Radome aft – pole forward of the backstay
4. Radome aft – pole aft of the backstay

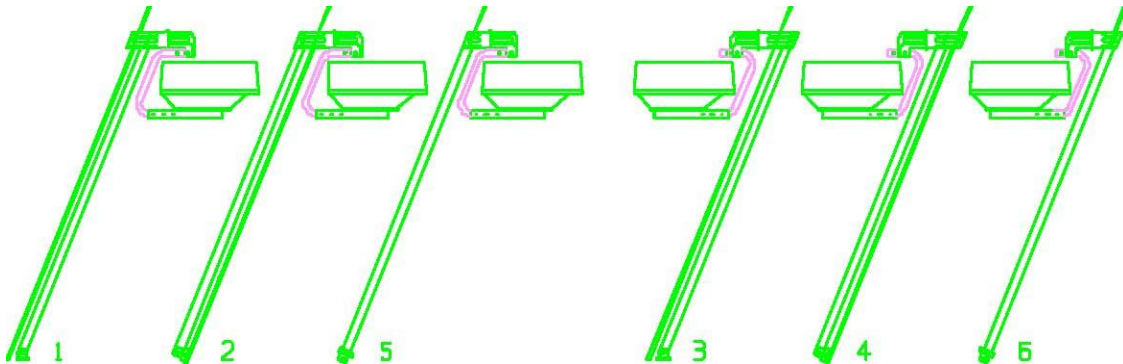

FIGURE 1

CHAINPLATE MOUNT (over the backstay)

5. Radome forward
6. Radome aft

REQUIRED TOOLS & FASTENERS * (*not supplied*):

- Drill and 1/4" drill bit - To mount the Pole Base to the deck or transom
- 7/16" box wrench – To assemble the antenna mounting plate to the cradle tube

* Consult the radar manufacturers' instructions for tools required for mounting the antenna & cable

ASSEMBLY MODEL 400G

Before deciding which assembly option to proceed with, you must determine the following characteristics about your vessel.

1. Do you have at least 2 feet of clearance between the backstay and the leach of the main sail at a point approximately 8 feet above the chainplate?

If the answer is *NO*, proceed with RADOME AFT configurations #3, #4 or #6

2. Do you have a topping lift which is usually loose that may catch the radome during a tack?

If the answer is *YES*, proceed with radome aft configurations #3, #4 or #6

3. Do you have a clevis pin at the chainplate that is larger than 3/8" diameter?

If the answer is *YES*, configurations #5 or #6 cannot be accomplished. Should you still desire this configuration, contact the factory for a custom pole base.

4. Do you have adequate space forward or aft of the backstay on the deck*, or transom to mount the pole base with the pole *centerline* 2 inches from the backstay and parallel to it?

* be sure to check below the deck to assure adequate space to through bolt the pole base

5. Do you have a split backstay?

If *YES*, are the legs of the split at least 8 feet 6 inches in length?"

If *YES*, proceed with the instructions for configurations #1, #2, #3, #4, #5 or #6

If *NO*, then configurations #1, #2, #3 or #4 can be installed on the boats centerline. The Pivot Damper Assembly will be above the split.

6. Do you have a hydraulic backstay adjuster?

If *YES*, proceed with instructions for configurations #1, #2, #3 or #4. Configurations #5 and #6 will require a hydraulic cylinder adapter.

The above questions may influence which mounting configuration you choose, however your own personal preference will be the deciding factor.

The following instructions are for configuration #1 and #4. For configuration #2 and #3 the Bushing Housings (2) and Backstay Bushing (1) as described in Step C, should be placed between the Pivot Base Mid Spacer (4) and the Pivot Base Cone (7). For configurations #5 and #6 additional steps “N” and “O” are required. Loctite should **NOT** be applied to any threads until the unit has been completely assembled and ascertained to be correct.

- A. Trial fit the backstay bushing (1) to your backstay to determine the appropriate groove to use. The bushing groove closest in size to the backstay should be used.
- B. Holding the backstay bushing against the aft side of the backstay, slide the upper and lower backstay bushing housings (2) around the backstay bushing. (Figure 3)
- C. Place the Pivot Base End Cap (3) around the open portion of the Backstay Bushing Housing and place the Pivot Base Mid-spacer (4) around the solid side of the Backstay Bushing Housing assembly. Insert two 5/16-18 x 3-1/2” Allen Head Cap Screws (6) through the Pivot Base End Cap and Pivot Base Mid Spacer. Attach this assembly to the Pivot Base Cone (7) by lightly tightening the Allen Head Cap Screws. (Figure 4)

NOTE: If the Single Antenna Kit SAK2 has been purchased it should be assembled at this step Refer to Page 12.

FIGURE 3

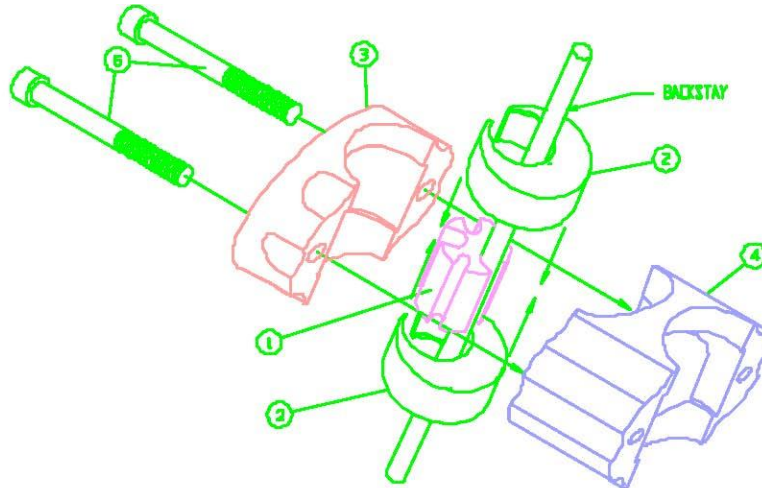
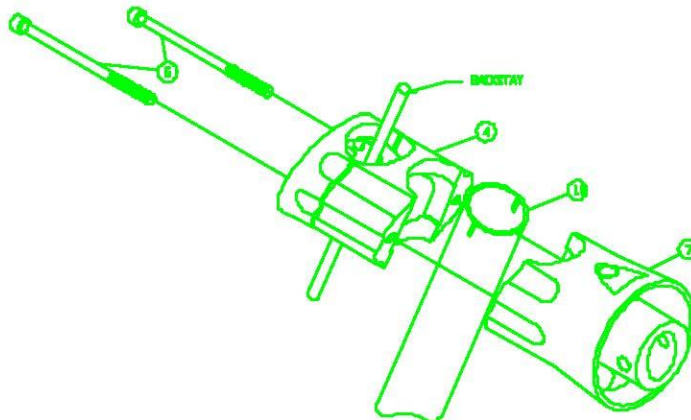

FIGURE 4



D. Slide the completed assembly up the backstay and insert the Mounting Pole (19) into the hole between the Mid Spacer (4) and the Pivot Base Cone (7) and secure it by lightly tightening the bolts (6).

E. Attach the Pole Base (9) to the lower end of the Mounting Pole (19) using the Clevis Pin (10), Clevis Pin Washer (11), and Cotter Pin (12). Place the Pole Base on the deck forward of the backstay (configuration #1 and #3) or aft of the backstay (configuration #2 and #4). Place the Pole Base on the deck (forward or aft) of the backstay so the distance between the backstay and the Mounting Pole is approximately 1-1/4". The Mounting Pole should now parallel the backstay and the Clevis Pin (12) should be athwartships. The Pivot Base Assembly should be located on the boats fore and aft centerline.

F. Using the Backing Plate (16) as a template, insert it under the Pole Base and mark the four screw holes on the deck.

G. Remove the Pole Base (9) and the Mounting Pole (19) from the Pivot Base by loosening the Allen Cap Screws (6). Slide the Base Assembly down the backstay until it rests on the backstay turnbuckle.

H. Using a drill with a 1/4" drill bit, drill 4 holes through the deck as previously marked with the Backing Plate. It is important that the holes be drilled parallel with each other to accommodate the Backing Plate under the deck.

I.....Apply adequate bedding compound to the Pole Base (9) and secure the Pole Base using four Hex Head Bolts (13), Backing Plate (16), four Flat washers (14), and four Self Locking Nuts (15) through the Pole Base and deck. (Figure 5)

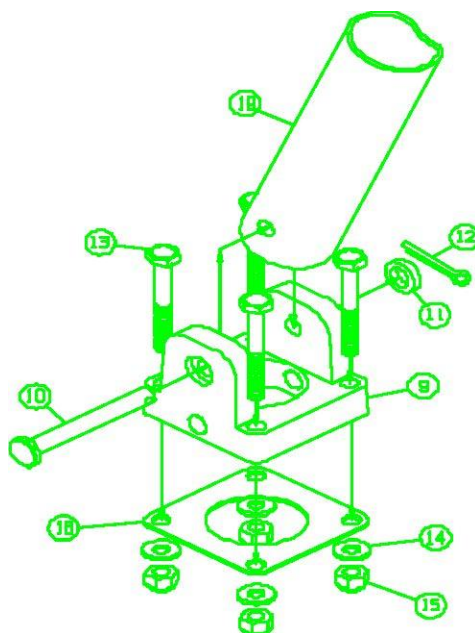

FIGURE 5

J. Feed the radar antenna cable through the deck until approximately 20 feet of wire is above the deck.

Note: For configurations #5 & #6 the Pole Base (9) must be assembled to the end of the Mounting Pole (19) using two Dog Setscrews (21). The unthreaded portion of each Setscrew must be inserted into the two 3/8" holes of the Mounting Pole.(Figure 8)

K. Feed the radar antenna cable through the bottom of the Mounting Pole (19), or through the Grommet in the lower slot and exit either from the Grommet in the upper slot or through the top of the Mounting Pole. The upper wire slot exit should be on the side **OPPOSITE** the Damper Assembly.

L. Insert the Anti-rotation Clip (20) into the slots of the Mounting Pole (19), (Figure 6).

M. Remove the Allen Cap Screw (6) from the Pivot Base Cone (7) and place the Cone aside. Attach the Mounting Pole (19) to the Pole Base (9) using the Clevis Pin (10), Clevis Pin Washer (11), and the Cotter Pin (12). Using a step ladder in the cockpit, slide the Pivot Base Assembly up the backstay and re-assemble the Pivot Base Cone. The Anti-rotation Clip tabs should be clamped between the Pivot Base Cone (7) and the Mid Spacer (4). Remove each clamping screw one at a time, apply Loctite, and reinstall each screw, alternately tightening each one, so that the gap between the three parts of the Pivot Damper Assembly are equally spaced. (Figure 6).

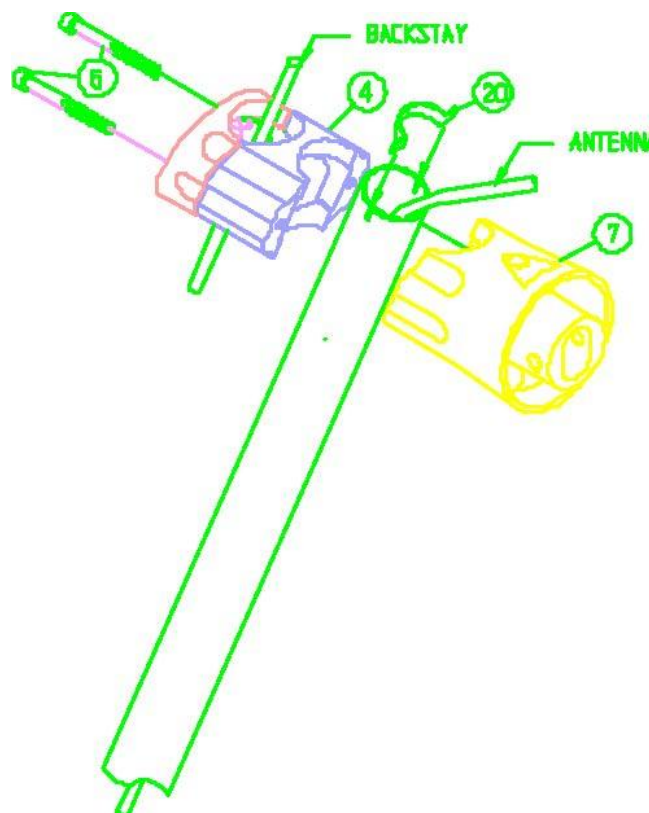

Figure 6

N. For configurations #5 or #6, remove the backstay turnbuckle from the backstay and set it aside. If the chainplate clevis pin centerline runs fore and aft, a toggle must be added so that the Clevis Pin (10) centerline will be athwartships. With the Anti-rotation Clip (20) inserted into the top of the Mounting Pole (19); slide the pole into the Pivot Base Cone until the top touches the bottom side of the lower Backstay Bushing Housing (2). Apply Loctite to the clamping screws (6) and tighten the assembly (Figure 7).

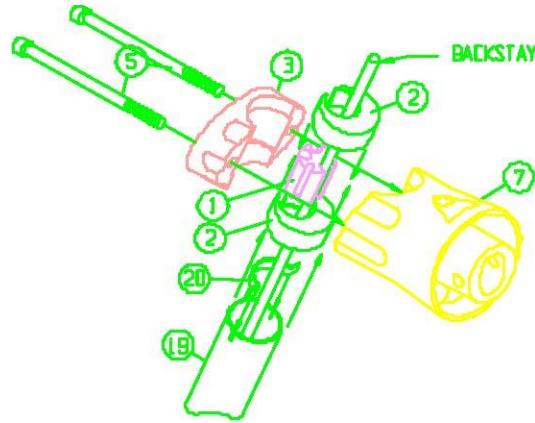

FIGURE 7

O. Feed the backstay through the top of the Mounting Pole (19). With the assistance of another person or with the main halyard, raise the pole and reconnect the turnbuckle to the backstay. Remove the two Dog Setscrews (21) from the Pole Base (9), pass the turnbuckle through Pole Base and re-connect the lower end of the turnbuckle to the chain plate, inserting the Clevis Pin (10) through the Pole Base, turnbuckle, chainplate and Pole Base again. Re-tension the backstay to the desired tension and then slide the Mounting Pole (19) into the Pole Base. Re-install the two Dog Setscrews (21) applying Loctite to each and tighten (Figure 8).

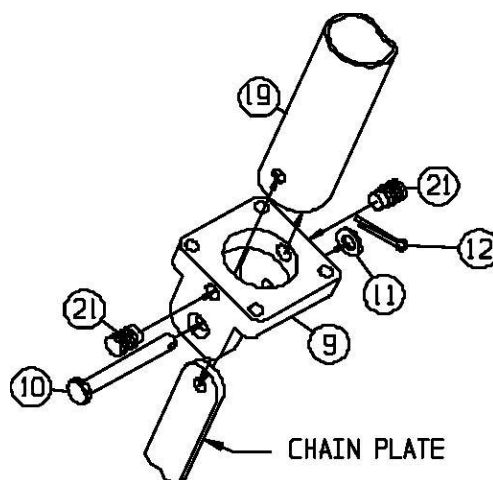

FIGURE 8

P. Assemble the Radar Antennae Mounting Plate (22) to the Cradle Tube (23) using the two Allen Head Cap Screws (24) and two Self Locking Nuts (15) (Figure 9).

Q. Insert the Cradle Tube (23) into the Damper Assembly (25) and screw in the Allen Cap Screw (26). Do not tighten at this time, ((Figure 9).

R. Install the two Setscrews (27) into the top and bottom holes of the Pivot Base Cone (7) until the screws are flush with the holes. Install the Damper/Cradle Assembly into the Pivot Base Cone (7). Apply Loctite to the threads on the Pivot screw (28) and install through the hole in the side of the Pivot Damper Assembly (25), and firmly screw it into the Pivot Base Cone (7).

S. Be sure the backstay is tensioned to its normal position. Adjust the top leveling Setscrew (27) until the Mounting Plate (22) is level fore and aft. Remove the Mounting Plate from the Cradle Tube (23) and secure the lower adjusting Setscrew (27) until the Pivot Damper shaft is firmly clamped between the two adjusting Setscrews. Insert the medium plug (29) in the top adjusting Setscrew hole of the Pivot Base Cone (7) (Figure 9).

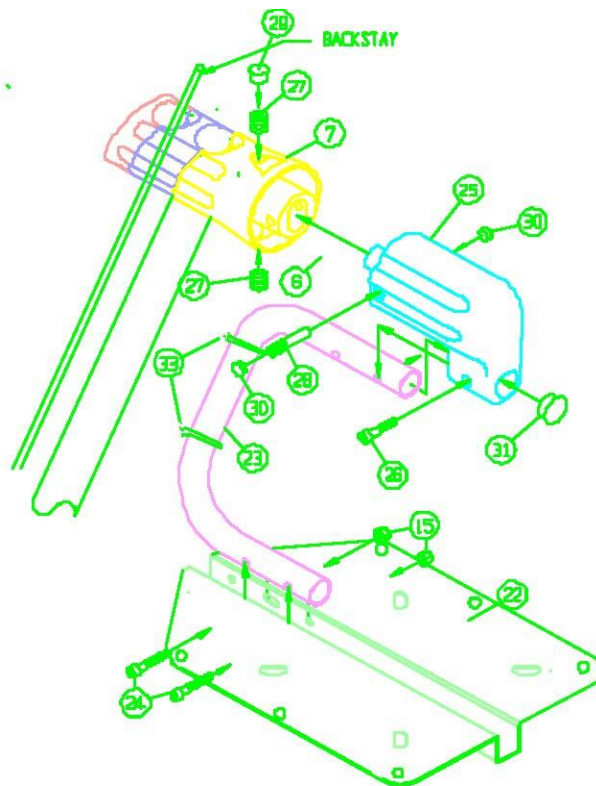

FIGURE 9

T. At this point, follow the radar manufacturer's instructions. Connect the antenna cable to radar dome and then secure it to the Mounting Plate (22). **NOTE:** After the radar antenna dome has been secured to the Mounting Plate and Cradle Tube and the Mounting Plate and Screws (24) secured, the radar antenna dome **cannot** be removed, without dis-assembly, when configured in the forward mounted option.

U. Re-install the Mounting Plate, Cradle Tube, and radar dome assembly. **NOTE:** If the GPS3 kit has been purchased, it should be installed at this step. See GPS3 Installation Instructions.

V. Feed any excess antenna cable down the inside of the Mounting Pole leaving a loop at the top, see (Figures 10 & 11). Use the cable ties (33) to attach the radar cable to the Cradle Tube (23). Insert the two small plugs (30) in the holes on either side of the Damper Assembly. Install the Large Plug (31) in the open end of the Cradle Tube.

You have now completed the installation.

Be sure that all screws have had Loctite applied and are adequately secured.

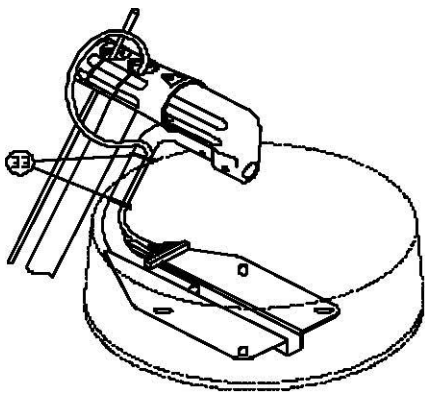

FIGURE 10

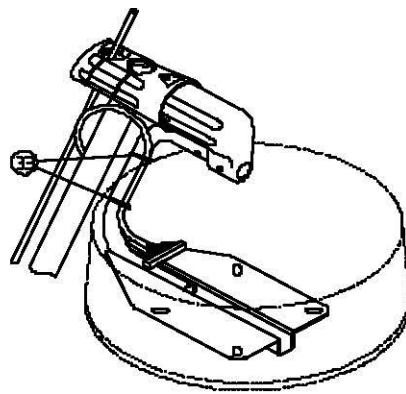

FIGURE 11

NOTE: The Questus Radar Mount Pivot Damper Assembly is filled with fluid and does not contain any customer serviceable parts. Disassembly should not be attempted.

MODEL 400G SELF LEVELING RADAR MOUNT PART DRAWING

Item numbers correspond with part numbers on following page.

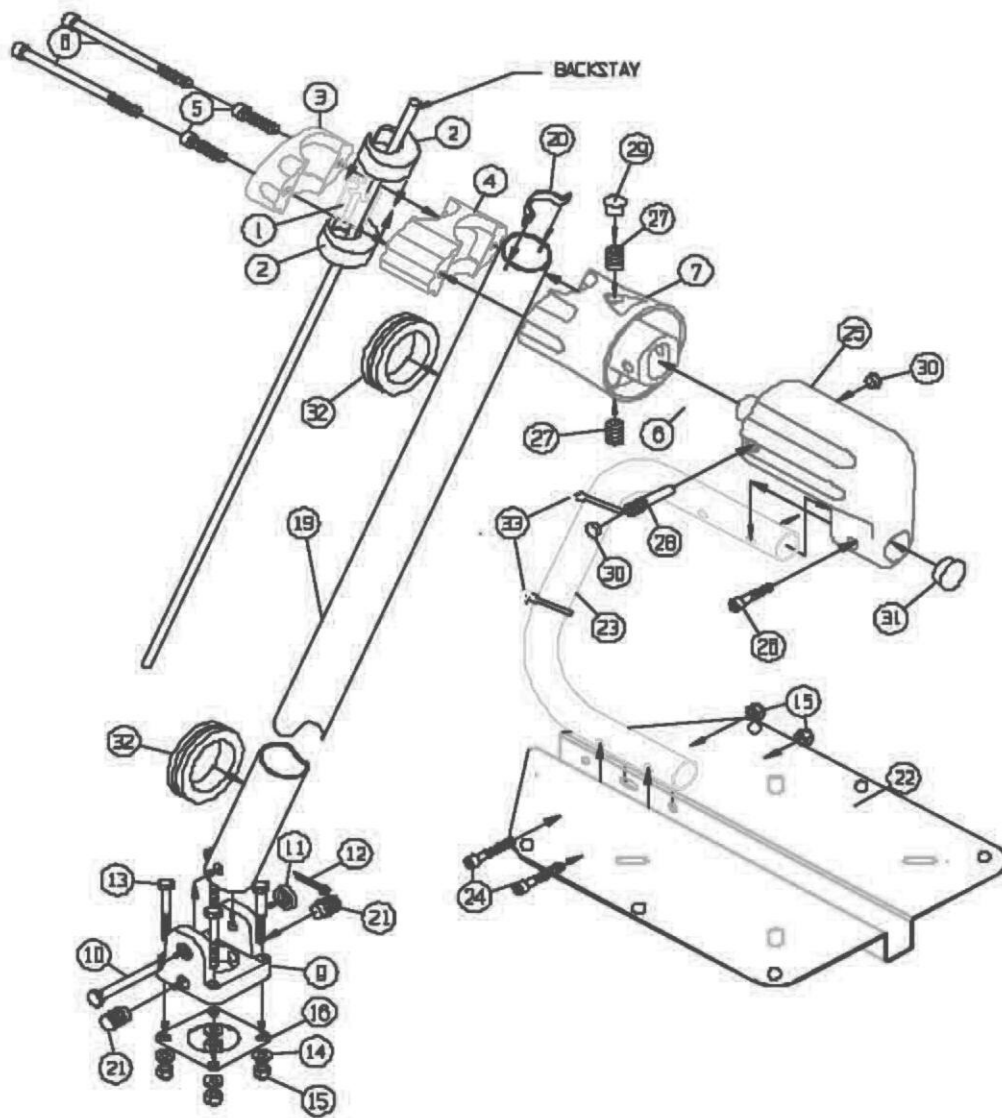

Figure 12

MODEL 400G
SELF-LEVELING RADAR MOUNT
PARTS LIST

ITEM #	PART #	DESCRIPTION	QTY
1	102494-000	Backstay Bushing	1
2	102495-000	Backstay Bushing Housing	1
3	102518-003	Pivot Base End Cap	1
4	102518-002	Pivot Base Mid-spacer	1
5	100104-025	5/16-18 x 1-1/4" Allen Cap Screw	2
6	100104-024	5/16-18 x 3-1/2" Allen Cap Screw	2
7	102518-001	Pivot Base Cone	1
9	102516-000	Pole Base	1
10	102514-000	3/8" Clevis Pin	1
11	102515-000	Clevis Pin Washer	1
12	102135-002	Cotter Pin	1
13	100351-003	1/4-20 x 3" Hex Head Bolts	4
14	100360-011	1/4" Flat Washer	4
15	100359-301	1/4-20 Self Locking Nut	6
16	102510-000	Backing Plate	1
19	102507-002	Mounting Pole	1
20	102509-000	Anti-rotation Clip	1
21	102512-000	7/16-20 x 5/8" Dog Set Screw	2
22	102493-000	Antenna Mounting Plate	1
23	102496-000	Cradle Tube	1
24	100104-017	1/4-20 x 1-1/2" Allen Head Cap Screw	2
25	102519-000	Pivot Damper Assembly	1
26	100104-022	1/4-20 x 1-1/4" Allen Head Cap Screw	1
27	100106-104	1/2-13 x 5/8" Allen Head Set Screw	2
28	102504-000	Threaded Pivot Pin	1
29	102239-004	Hole Plug (medium)	1
30	102239-003	Hole Plug (small)	2
31	102239-002	Hole Plug (large)	1
32	102273-101	Grommets	2
33	100379-003	Cable Ties	3
NOT SHOWN IN DIAGRAM			
34	100161-018	Loctite Capsule	1
35	102229-019	5/32" Allen Wrench	1
36	102229-011	3/16" Allen Wrench	1
37	102229-013	1/4" Allen Wrench	1

INSTALLATION INSTRUCTIONS

MODEL 400G

SAK2 SINGLE ANTENNA KIT

- The SAK2 Antenna Kit contains the following parts:

<u>ITEM</u>	<u>PART #</u>	<u>PART NAME</u>
34	100161-019	Loctite Capsule
38	102506-000	Antenna Bracket
39	102096-000	Antenna Bushing

- The SAK2 Bracket is designed to be installed astern of the backstay. Therefore the Pivot Base Clamping bolts (6) must be removed from the Pivot Base End Cap (3). The SAK2 Bracket is to be inserted between the castings and line up with the bolt holes of the Pivot Base End Cap (3) and the Pivot Base Mid-spacer (4). (Figure 13) or (Figure 14).

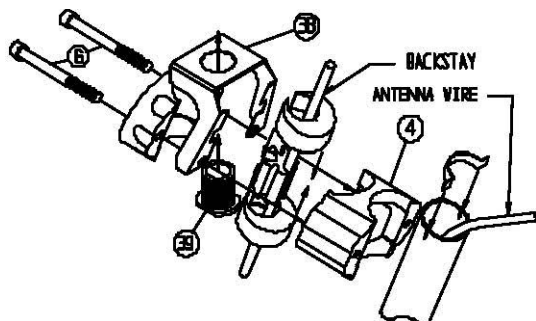

FIGURE 13

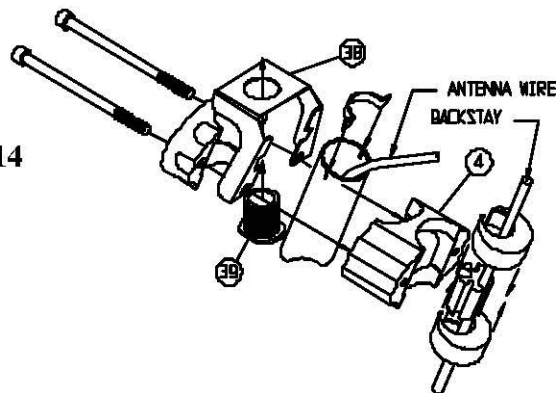

FIGURE 14

- Apply Loctite to the threads of the two clamping bolts and re-install, clamping the SAK2 Bracket in place and re-tighten the Pivot Base Assembly.
- Insert the Antenna Bushing (39) in the Bracket (38) hole and secure it to you antenna. Wiring for the additional antenna can enter the Mounting Pole either through the top or the side.

Installation is now complete.

INSTALLATION INSTRUCTIONS MODEL 400G DBA2 DOUBLE ANTENNA KIT

1. The DBA2 Double Antenna Kit consists of the following parts.

<u>ITEM</u>	<u>PART #</u>	<u>DESCRIPTION</u>
34	100161-018	Loctite
39	102096-000	Antenna Bushings
40	102527-000	Antenna Bracket
41	100351-002	1/2-13 SS Hex Head Bolt
42	100361-007	1/2" SS Washer

2. The DBA2 Bracket assembly mounts on the flat surface on the topside of the Pivot Base Cone. Apply Loctite to the threads of the Hex Head Bolt (41). Insert the Bolt through the Lockwasher and then through the center hole of the Bracket (40) then tighten in the top adjustment screw hole of the Pivot Base Cone. (Figure 15)
3. Insert the Antenna Bushings (39) in the Antenna Bracket (40) and affix the antennae.

Note: The wires for the antennae can enter the pole through either the top or the side.

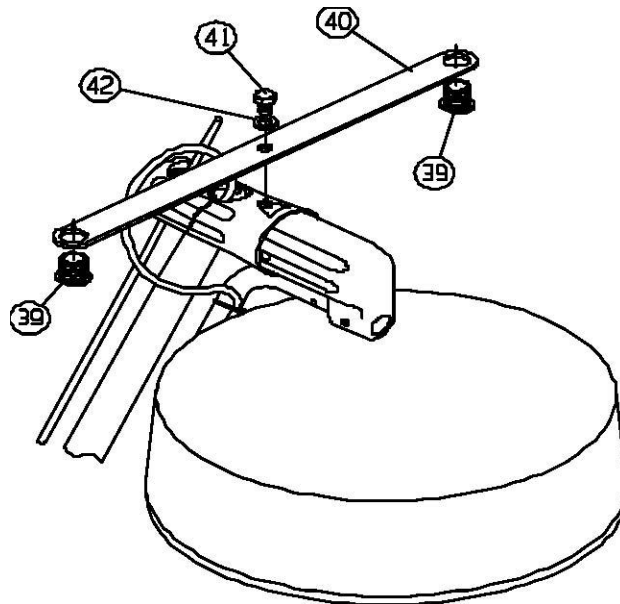

FIGURE 15

INSTALLATION INSTRUCTIONS

MODEL 400G & 500G

GPS3 ANTENNA KIT

1. The GPS3 Antenna Kit contains the following parts:

<u>ITEM</u>	<u>PART #</u>	<u>PART NAME</u>
34	100161-018	Loctite capsule
43	102523-000	GPS3 Bracket

2. The GPS3 Bracket (43) is to be inserted in the top of the Cradle Tube (23) and is secured using the same socket cap screw (26) that holds the cradle tube to the damper assembly. **NOTE** If you have chosen an aft cradle configuration, you will need an additional 1/4-20 x 1-1/4" screw, lock washer and nut to assemble the GPS3 bracket to the cradle tube extending from the damper assembly. An alternative installation is to cut the cradle tube that extends from the damper assembly and use the existing cradle tube/damper clamping screw (26).

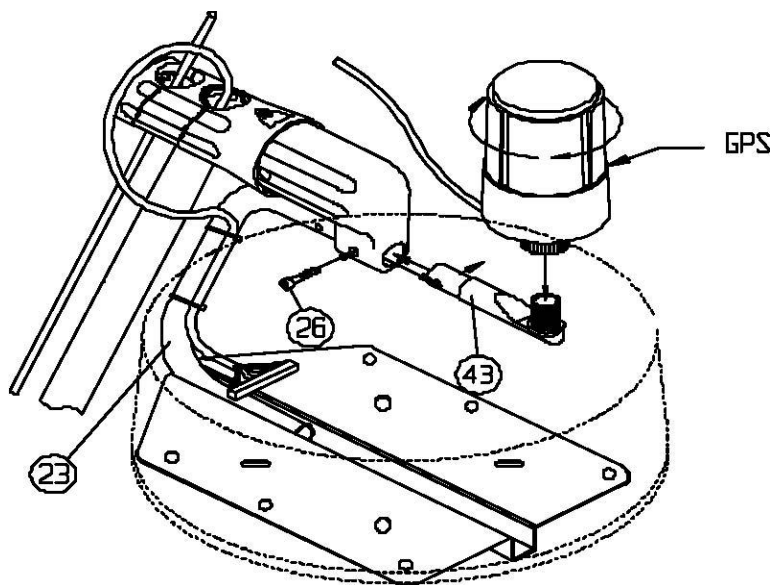

FIGURE 16

3. Remove the cradle tube clamping screw (26). Insert the GPS3 bracket (43) into the open end of the cradle tube and reinstall the screw with Loctite to clamp both tubes to the damper assembly.
4. Screw on the GPS antenna to the bracket and run the wire inside the mounting tube from the top or through the grommet.

QUESTUS LIMITED WARRANTY



I WARRANTY: Questus Marine, Inc. warrants that self Leveling Radar Mount products will be free from defects in materials and workmanship for a period of one year. Any part which proves defective in normal usage during the one year period will be repaired or replaced by Questus Marine, Inc.

This warranty is subject to the following conditions and limitations:

- A) Questus Marine, Inc.'s liability shall be limited to repair or replacement, at Questus Marine, Inc.'s discretion, of goods or parts defective in materials or workmanship. This shall be the buyers exclusive remedy.
- B) Except where otherwise specified, quality shall be in accordance with Questus Marine, Inc. specifications.
- C) The Self Leveling Radar Mount must be installed and maintained properly and used under normal conditions in the application for which it was intended.
- D) This warranty does not apply to any products that were improperly installed or maintained, or subject to misuse or negligence during normal operation and storage.
- E) Questus Marine, Inc. shall not be responsible for shipping charges or installation labor associated with any warranty claims.

II Failure to follow installation instructions or otherwise be aware of the information contained in the installation instructions may void this warranty.

III The limited warranty is in lieu of all other warranties; any implied warranties are limited in duration to the duration of the warranty stated here.

IV Questus Marine, Inc. is not responsible for consequential damage of any sort, to the extent that such exclusion is permitted by applicable law.